

AD120

1. SPECIFICATIONS

Copy Paper Size:	A4 and B5/8 1/2" x 11" (sideways)
Paper Weight:	59 to 104 g/m ² (16 to 27 lb)
Paper Stack:	50 sheets
Dimension (W x D x H):	516 x 529 x 90 mm (20.4" x 20.9" x 3.6")
Weight:	Approximately 5 kg (11 lb)

- Specifications are subject to change without notice.

2. COMPONENT LAYOUT

— Mechanical Components —

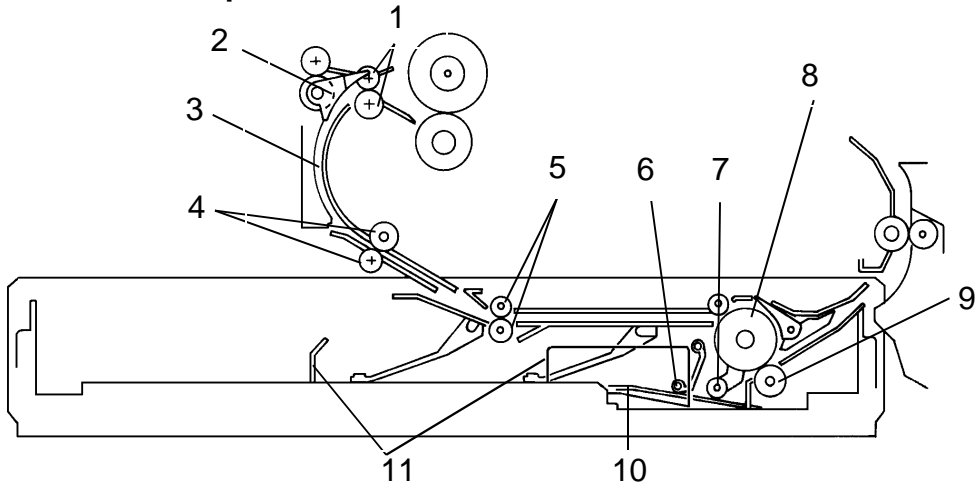

- | | |
|-----------------------|-------------------------|
| 1. Duplex Gate Roller | 7. Paper Flattener |
| 2. Duplex Gate | 8. Duplex Feed Roller |
| 3. Turn Guide Plate | 9. Friction Roller |
| 4. Transport Roller | 10. Duplex Bottom Plate |
| 5. Entrance Roller | 11. Jogger Fences |
| 6. Paper End Feeler | |

— Electrical Components —

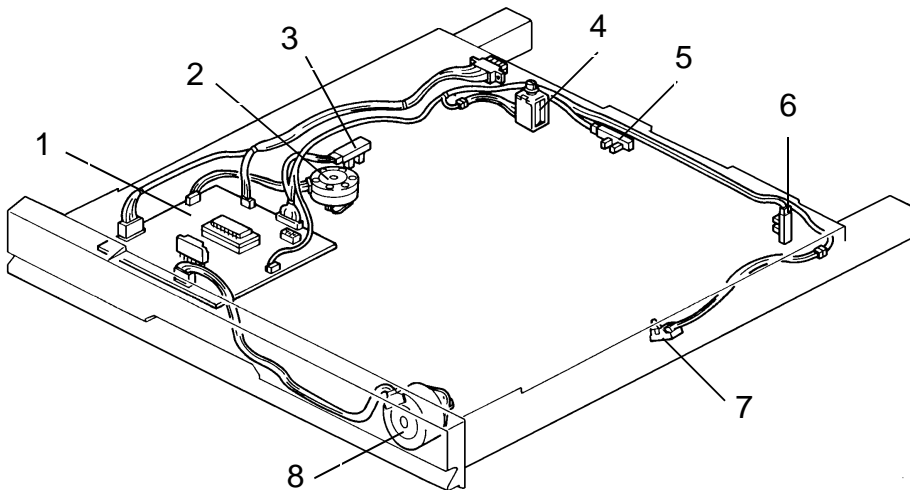

- | | |
|-------------------------|----------------------------|
| 1. Main Board | 5. Duplex Entrance Sensor |
| 2. Jogger Motor | 6. Duplex Paper End Sensor |
| 3. Jogger HP Sensor | 7. Duplex Turn Sensor |
| 4. Duplex Gate Solenoid | 8. Duplex Feed Motor |

3. ELECTRICAL COMPONENT DESCRIPTION

SYMBOL	NAME	FUNCTION	INDEX NO.
Motors			
M1	Duplex Feed Motor	Stepper motor (24 Vdc) drives feed roller and moves the bottom plate up and down.	8
M2	Jogger Motor	Stepper motor (24 Vdc) drives the jogger fences to square the paper stack on the duplex tray.	2
Solenoids			
SOL 1	Duplex Gate Solenoid	Moves the duplex gate to direct copies to the duplex tray or to the paper exit.	4
Sensors			
S1	Duplex Entrance Sensor	Detects copy at the entrance.	5
S2	Duplex Turn Sensor	Detects copy in the turn section.	7
S3	Duplex Paper End Sensor	Detects copy in the duplex tray.	6
S4	Jogger Home Position Sensor	Detects whether the jogger fences are at home position.	3
Printed Circuit Board			
PCB1	Duplex Main Board	Controls all duplex unit functions.	1

4. POWER DISTRIBUTION AND OVERALL MACHINE CONTROL

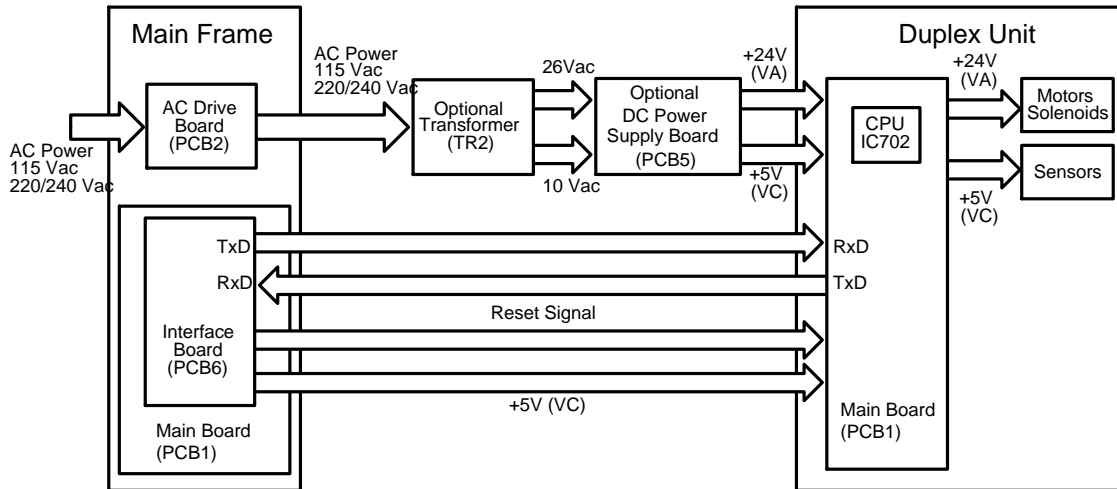

When the main switch is turned on, the optional transformer receives wall outlet ac power through the ac drive board and outputs 10 volts ac and 26 volts ac to the optional dc power supply board. The optional dc power supply board then converts the 10 volts ac input to +5 volts and the 26 volts ac input to +24 volts. Then, the +5 volts and +24 volts are supplied to the duplex unit main board. The interface board also provides +5 volts to the duplex unit main board and sends a reset signal to initialize the duplex unit CPU.

The duplex unit main board supplies dc power to all electrical components in the duplex unit. All motors and solenoid operate on +24 volts and all sensors operate on +5 volts.

The duplex unit has its own CPU which controls all functions in the duplex unit. The duplex unit CPU communicates with the copier through the interface board using a serial interface.

5. BASIC OPERATION

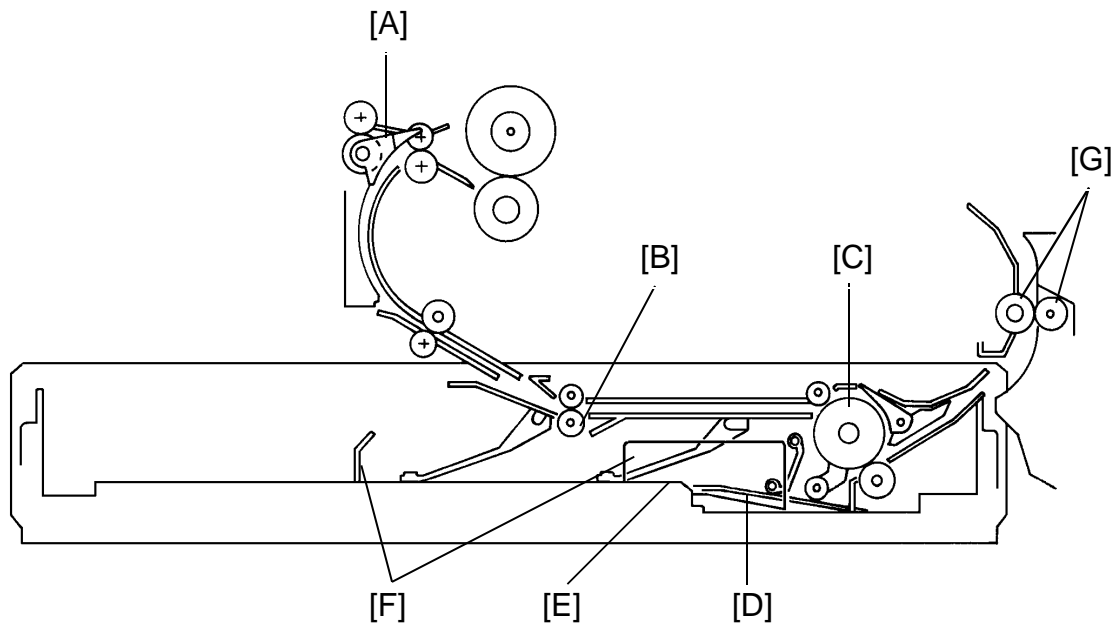

5.1 FIRST SIDE COPY

When the registration clutch turns on, the duplex gate [A] rotates up to direct the copy to the duplex unit. The entrance roller [B] and duplex feed roller [C] then start to rotate. At the same time, the duplex bottom plate [D] lowers.

5.2 DUPLEX STACKING

After the copy is delivered to the duplex tray [E], the jogger fences [F] move inward to square the copy stack, then move back 10 mm. After the final copy is delivered to the tray, the jogger fences remain against the paper stack.

5.3 SECOND SIDE COPY

Soon after the final copy is squared by the jogger fences, the duplex bottom plate raises up to the final position and the duplex feed rollers start rotating counterclockwise (front view) to feed the copy to the relay rollers [G]. Second side copying is then done with the copy following the second feed station paper path.

6. DRIVE MECHANISM

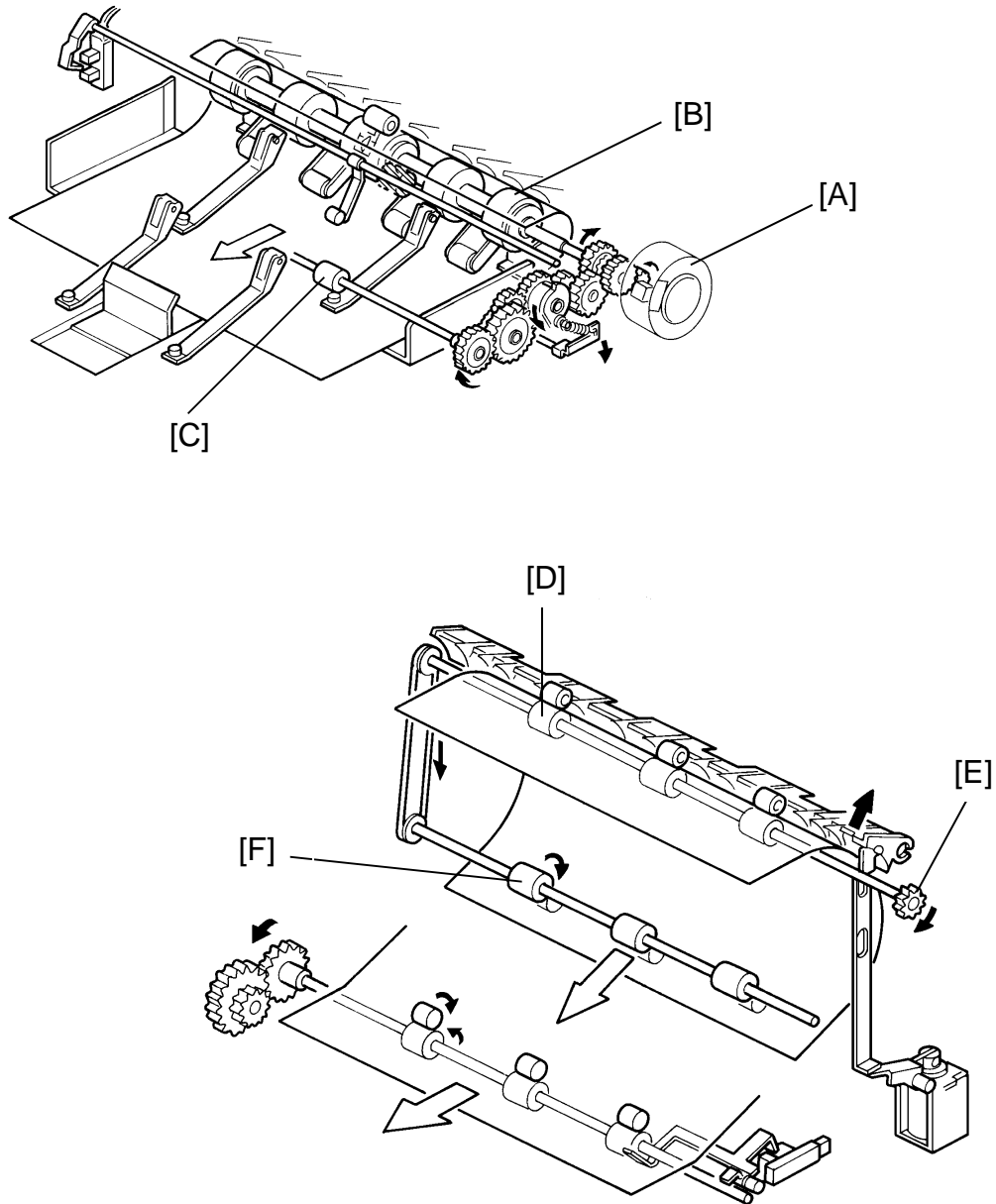

Drive is transmitted from the duplex feed motor [A] to the duplex feed rollers [B] and the entrance rollers [C] through a series of gears. A relay gear in the copier exit section transmits drive to the duplex gate rollers [D] through the duplex transport gear [E]. A rubber belt on the end of the duplex gate roller shaft drives the transport rollers [F].

The duplex feed motor also drives the duplex bottom plate up and down.

7. FIRST SIDE COPY

7.1 FROM COPIER PAPER FEED SECTION TO DUPLEX ENTRANCE ROLLER

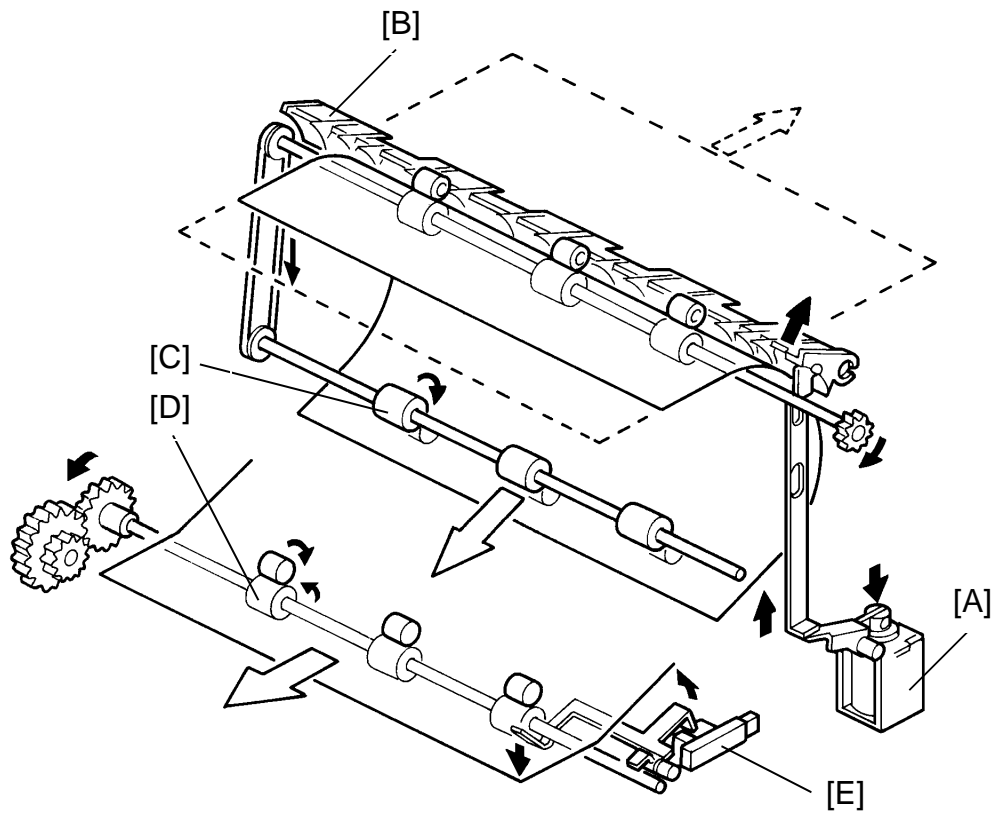

When the copier 1st paper feed clutch turns on, the jogger motor turns on and drives the three jogger fences into position 10 mm from the edges of the copy paper. (This position is determined by cassette coding.) The registration clutch then turns on and the duplex gate solenoid [A] energizes to raise the duplex gate [B]. The duplex gate solenoid stays on until first side copying is finished.

The copy is then directed to the duplex turn guide, where it is fed by the transport rollers [C] to the entrance rollers [D]. The leading edge of the copy activates the duplex entrance sensor [E], which is monitored by the duplex CPU to detect misfeeds.

7.2 FROM DUPLEX ENTRANCE ROLLER TO DUPLEX TRAY

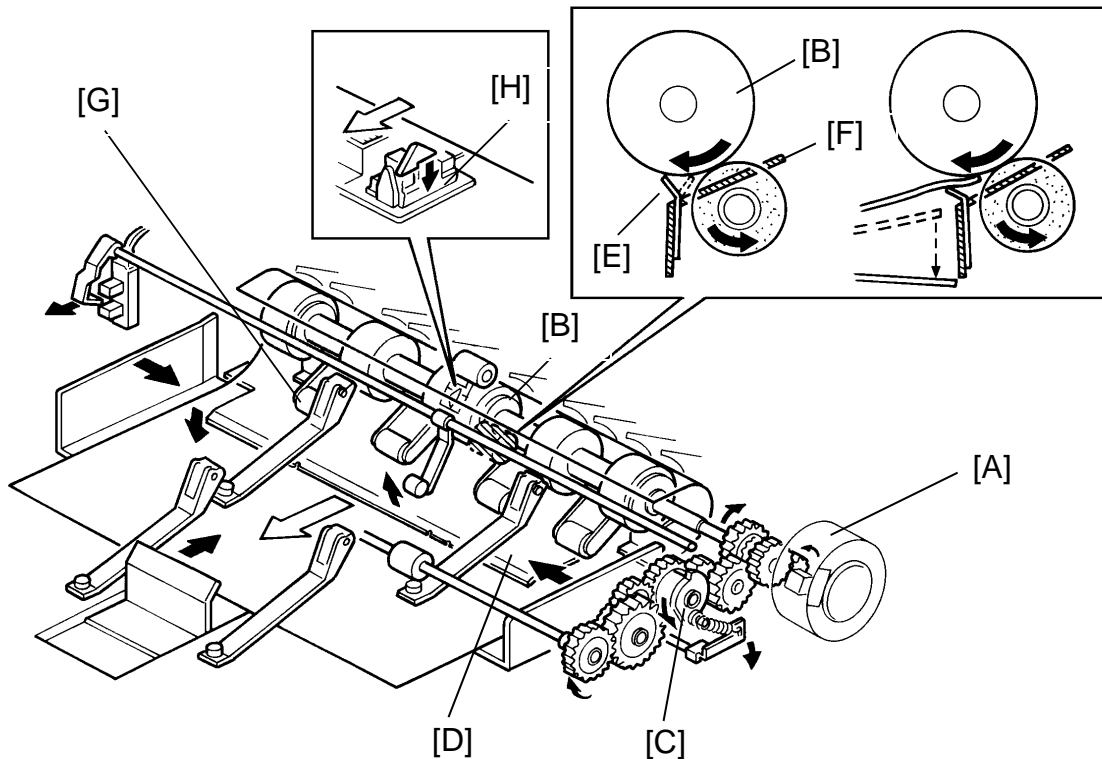

300 milliseconds after the duplex gate solenoid energizes, the duplex paper feed motor [A] starts turning counterclockwise (front view). Gears drive the duplex feed rollers [B] clockwise and the cam clutch [C] counterclockwise (front view). The cam clutch rotation lowers the duplex bottom plate [D].

The tip of the flip mylar [E] moves to the left (front view) when the duplex feed rollers rotate to feed the copy into the duplex tray. The mylar presses the copy against the rollers, ensuring that the trailing edge of the copy clears the guide plate [F]. The paper flatteners [G] correct curl on the leading edge of the copies. The leading edge of the copy actuates the duplex turn sensor [H], which is monitored by the duplex CPU to detect misfeeds.

7.3 DUPLEX STACKING

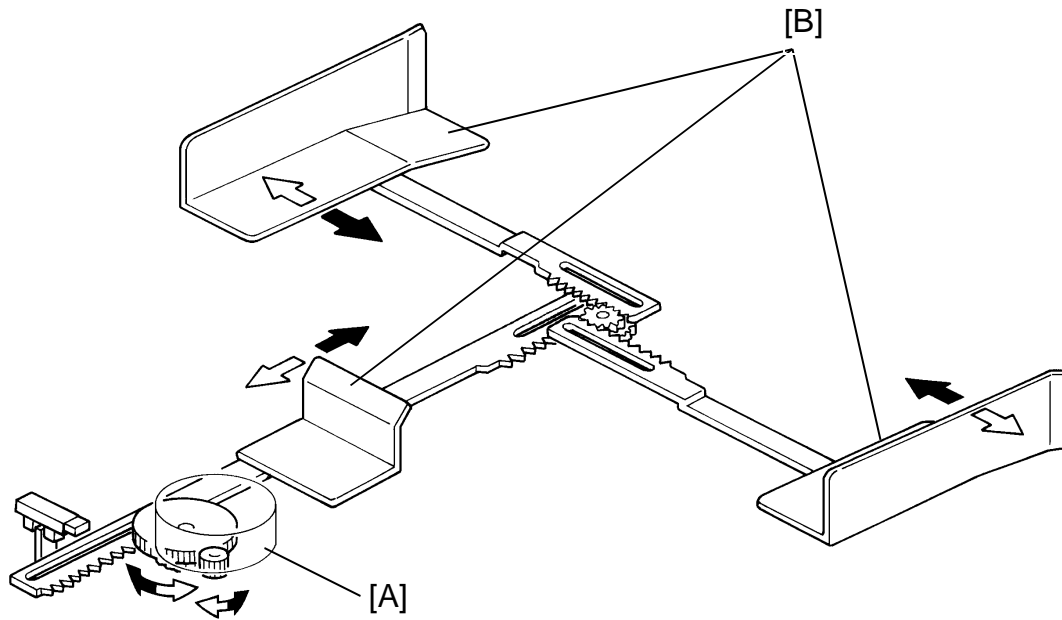

2,150 milliseconds after the duplex turn sensor is actuated by the leading edge of the copy, the jogger motor [A] rotates to drive the jogger fences [B] inward to square the paper stack, then the fences move back 10 mm. After the last copy of the first side copying run enters the duplex tray, the fences remain against the stack.

8. SECOND SIDE COPY

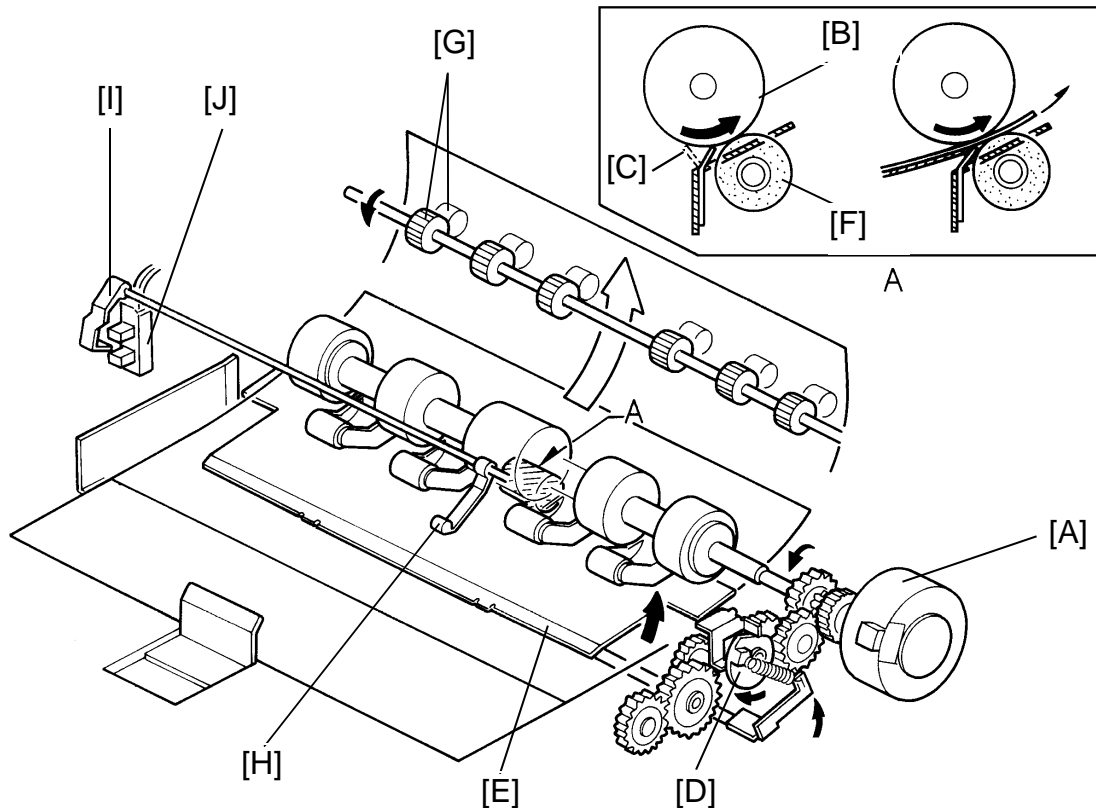

2,350 milliseconds after the duplex turn sensor is actuated by the leading edge of the final copy in the first side copy run, the duplex feed motor [A] reverses direction and rotates clockwise (front view), rotating the duplex feed roller [B] counterclockwise (front view). This moves the flip mylar [C] back to the right (front view). At the same time the cam clutch [D] rotates clockwise (front view), raising the duplex bottom plate [E].

The paper feed system, which consists of the duplex feed roller [B] and the friction roller [F], feeds only the top sheet of the stack copies to the relay rollers [G] in the copier. After that, the second side copies follow the second feed station paper path.

After the final copy leaves the duplex bottom plate, the paper end feeler [H] drops through a slot in the duplex bottom plate. The paper end actuator [I], which is on the same shaft as the paper end feeler, pivots into the duplex paper end sensor [J], sending a High signal to the main board to stop the next paper feeding cycle.

9. DUPLEX PAPER FEED AND MISFEED DETECTION TIMING

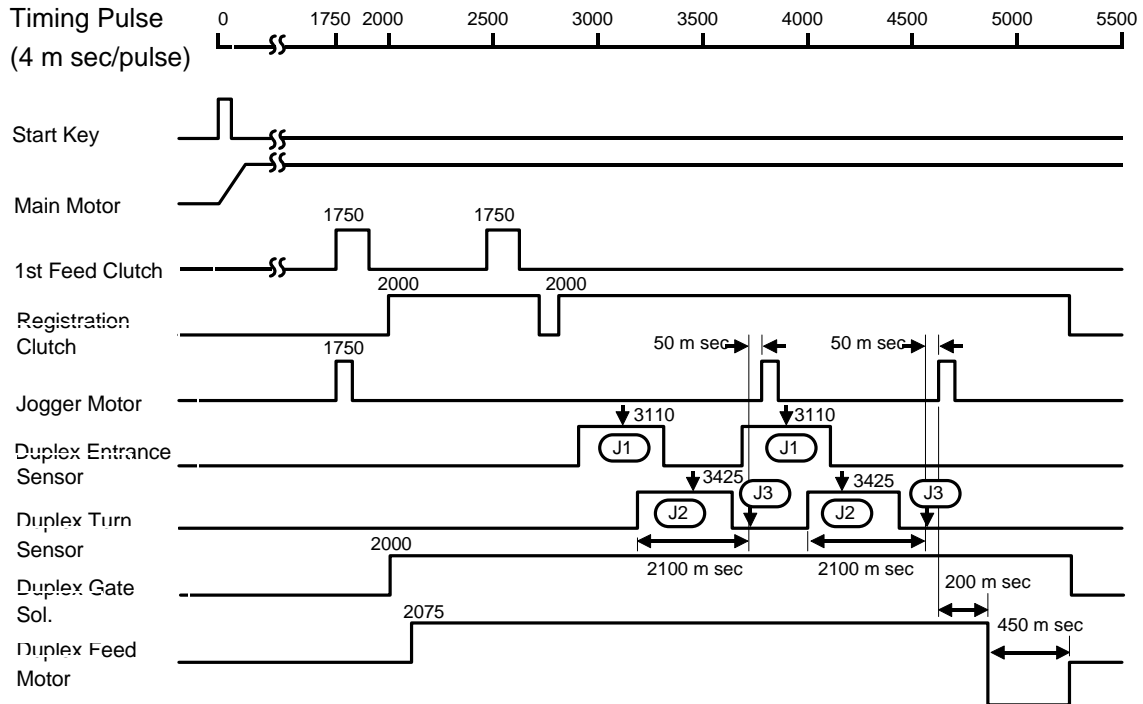

The duplex entrance sensor and the duplex turn sensor monitor the movement of the paper through the paper path in duplex mode. If the duplex CPU determines that a misfeed exists, the duplex CPU sends a misfeed signal to the copier CPU through the interface board, and the Check Paper Path and the Misfeed Location indicators turn on. When the main switch is turned on, the CPU checks these two sensors for initial misfeed. During the first side copy cycle, the duplex CPU performs three kinds of misfeed detection:

- J1: Checks whether the duplex entrance sensor is actuated within 1,110 pulses (about 4.4 seconds) after the registration clutch turns on. (The Misfeed Location indicator "D" turns on.)
- J2: Checks whether the duplex turn sensor is actuated within 1,315 pulses (about 5.3 seconds) after the registration clutch turns on. (The Misfeed Location indicator "E" turns on.)
- J3: Checks whether the copy paper passes through the duplex entrance sensor 525 pulses (2.1 seconds) after the duplex turn sensor has been actuated. (The Misfeed Location indicator "E" turns on.)

In the second side copy cycle, the misfeed detection timing is same as the one in the second feed station copying.

10. SERVICE CALL CONDITIONS

Service Code 80: Duplex and Copier Main Board Communication Error

The copier main board does not receive any signal from the duplex main board.

Service Code 81: Interface Board Error

The interface board is not connected when the duplex unit is installed.

Service Code 82: Jogger Home Position Error

The output of the jogger home position sensor remains LOW as the duplex main board is driving the jogger fences outward.

Service Code 83: Jogger Home Position Error

The output of the jogger home position sensor remains HIGH as the duplex main board is driving the jogger fences inward.

11. DUPLEX UNIT INSTALLATION

11.1 ACCESSORY CHECK

Check the quantity and condition of the accessories in the box according to the following list:

1. Turn Guide Plate	1
2. Roller	3
3. Connector Bracket	1
4. Shoulder Screw	2
5. Philips Pan Head Screw - M3 x 6	4
6. Tray Cover	1

- NOTE:**
1. When the duplex unit is installed on the copier, the DC Power Supply Unit (option) is required.
 2. When installing the DC Power Supply Unit, please refer to the installation procedure enclosed with it.

11.2 INSTALLATION PROCEDURE

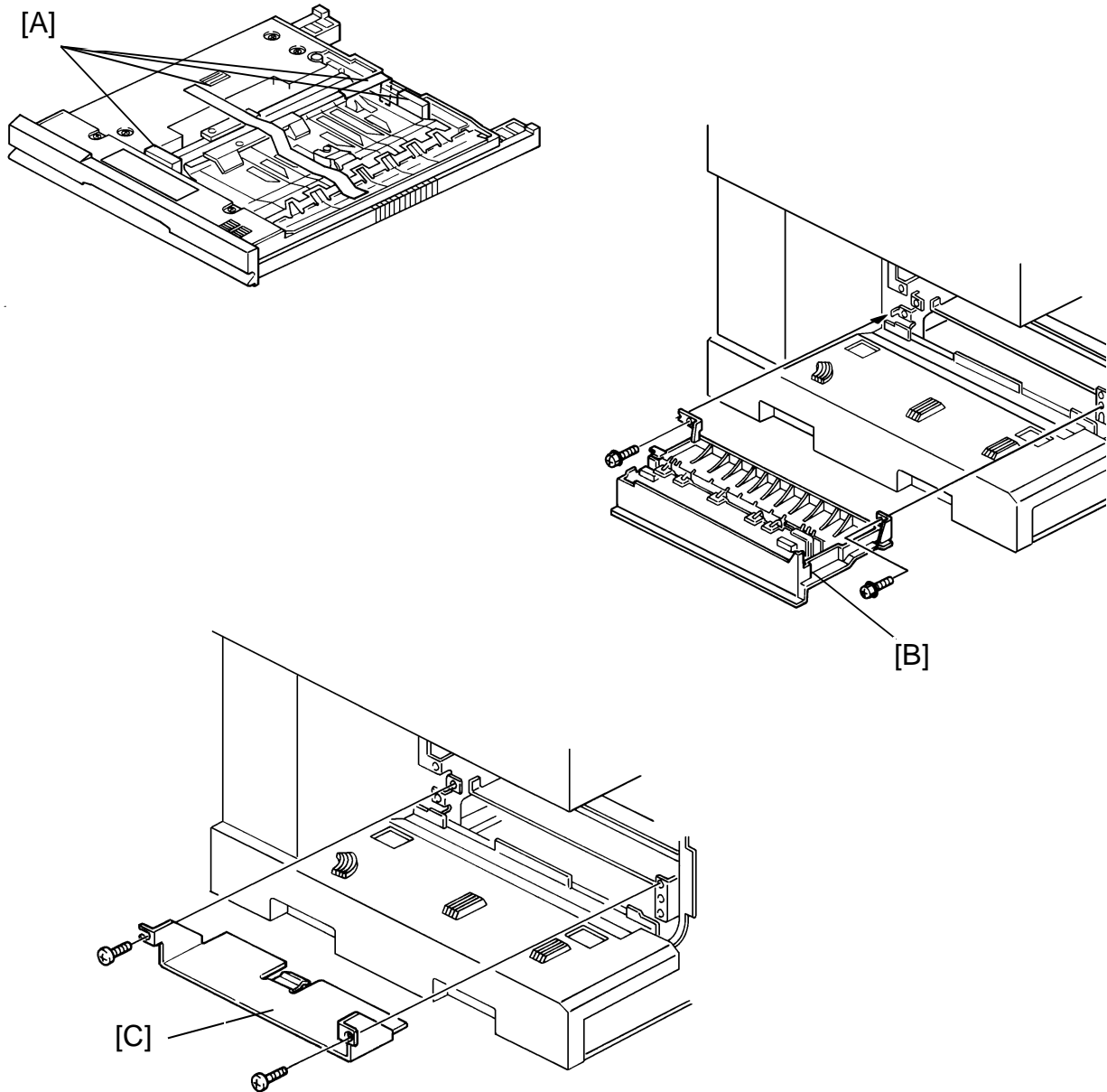

1. Turn off the main switch and unplug the copier power supply cord.
2. Install the dc power supply unit.
3. Remove the strips and styrofoam blocks [A].
4. Open the exit unit [B] and remove it (2 screws).
5. Remove the fusing bottom plate [C].

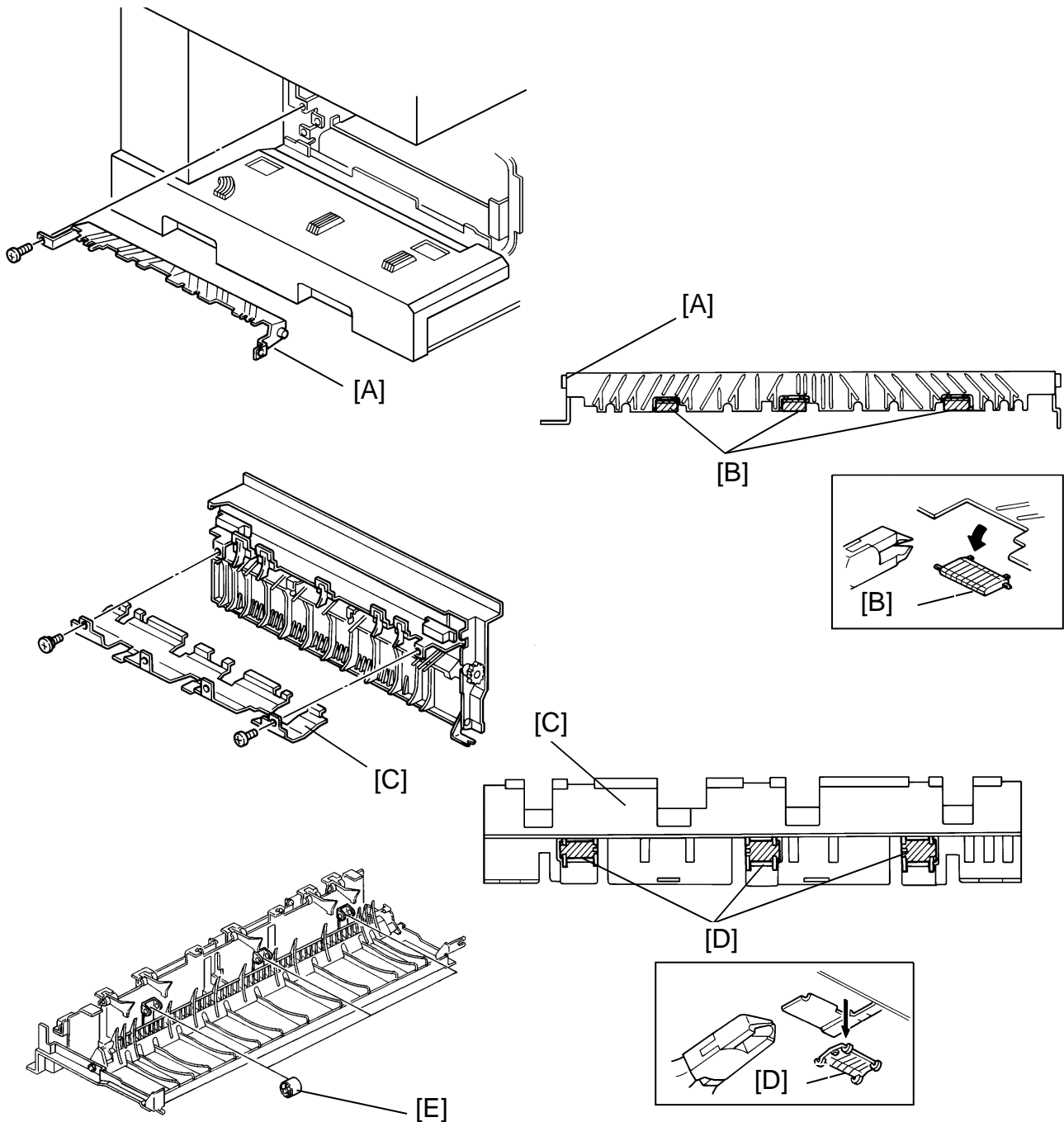

6. Remove the exit paper guide [A] (1 screw), and remove the stubs [B] with nippers and reinstall the exit paper guide.
7. Remove the upper paper guide [C] on the exit unit (2 screws) and remove the stubs [D] with nippers.
8. Install the three rollers [E] on the exit unit as shown.
9. Reinstall the upper paper guide plate [C] on the exit unit.

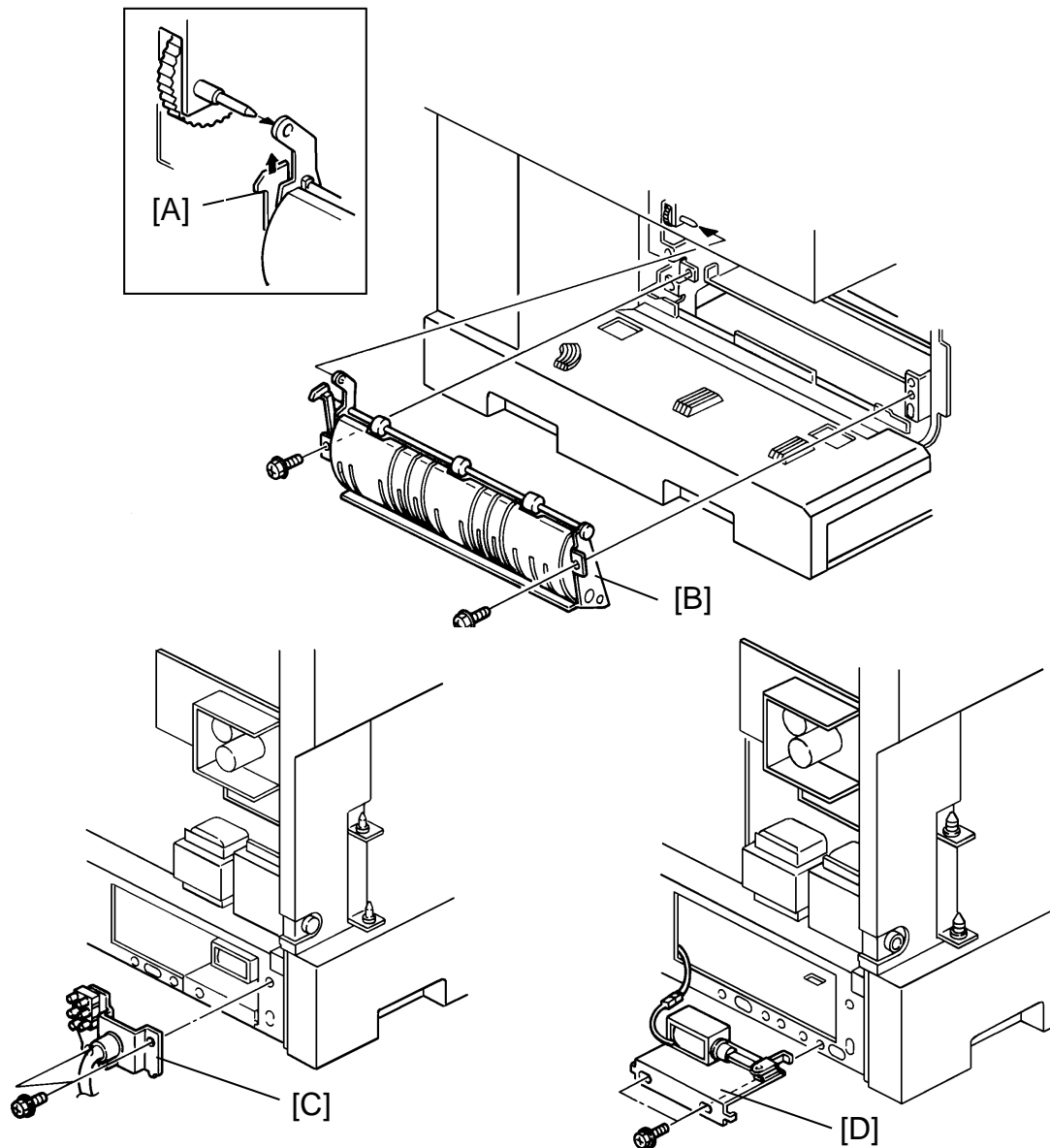

10. While pushing up the duplex gate lever [A], install the turn guide plate [B] (2 screws).
11. Reinstall the exit unit (2 screws).
12. Remove the paper tray from the copier if it is installed.
13. Remove the power supply cord bracket [C] (2 screws).
14. Remove the tray lock solenoid bracket [D] (1 screw).

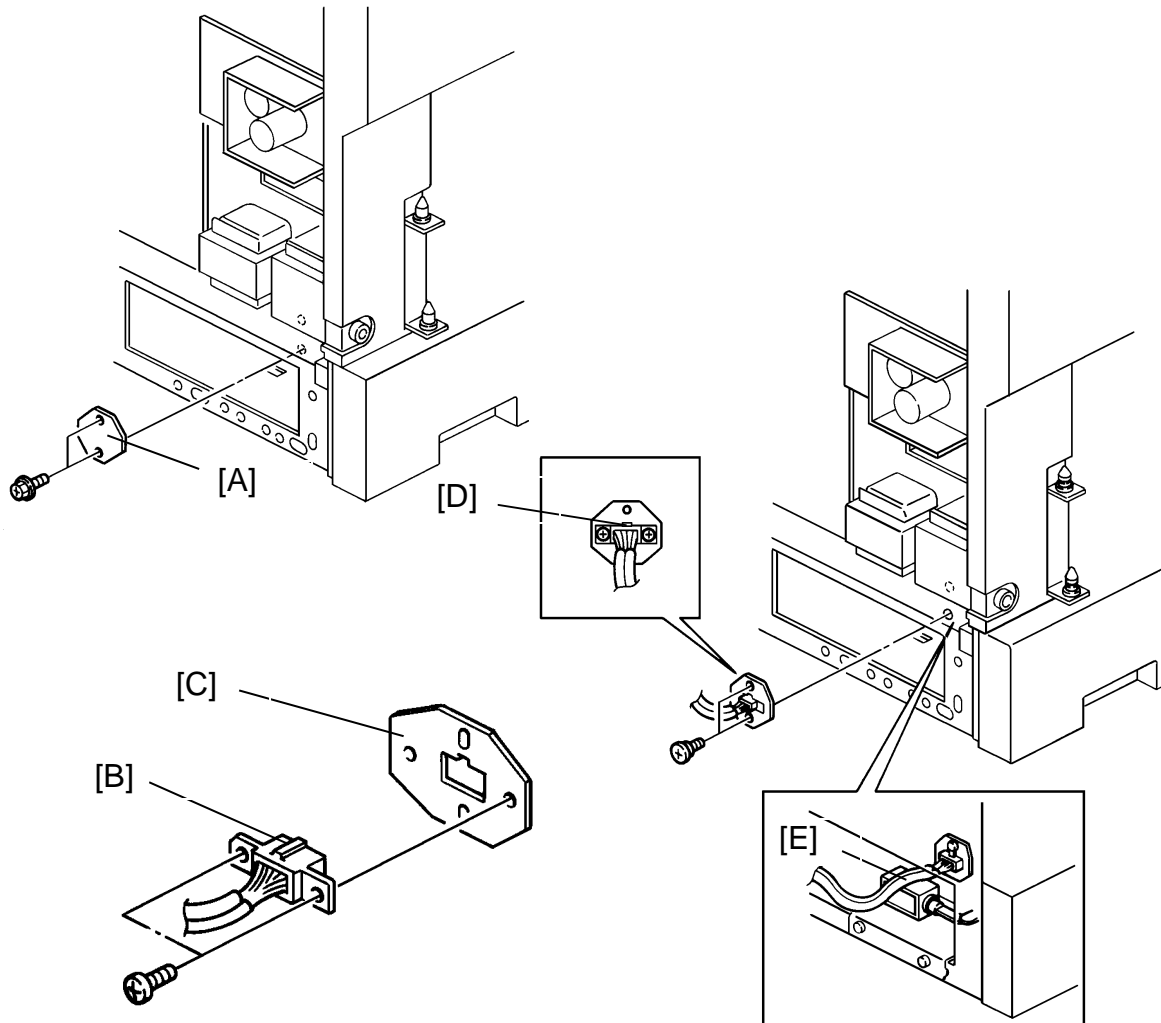

15. Remove the duplex connector cover plate [A] (2 screws).

NOTE: The cover plate can be thrown away.

16. Secure the optional harness duplex connector (8P/Black) [B] to the connector bracket [C] (2 screws).

NOTE: When installing the bracket, make sure that the cut-out [D] on the bracket faces up as shown.

17. Secure the connector bracket to the rear frame (2 shoulder screws).

NOTE: Make sure that the duplex harness [E] does not interfere with lock solenoid movement.

18. Reinstall all the brackets.

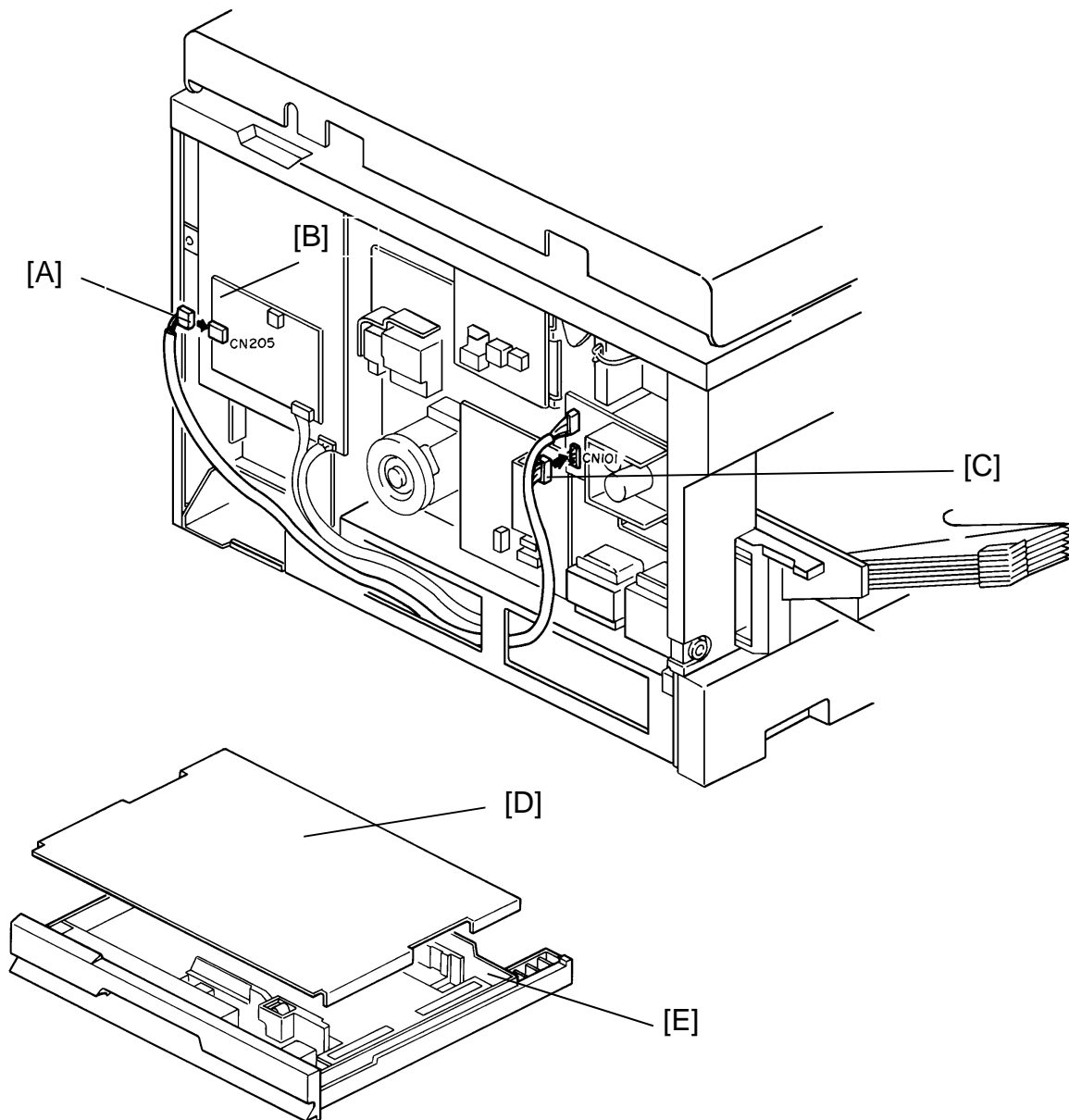

19. Connect the optional harness connector (4P/Black) [A] to CN205 on the interface board [B].
20. Connect the dc harness (4P/White) [C] to CN101 on the optional dc power supply unit.
21. Reinstall the rear cover (2 screws).
22. Insert the duplex unit into the copier.
23. Plug in the copier power supply cord and turn on the main switch.
24. Check the operation of the duplex unit.
25. Attach the tray cover [D] on the paper tray [E] as shown.

NOTE: Explain to the customer how to install the tray cover.

12. REPLACEMENT AND ADJUSTMENT

12.1 DUPLEX TRAY REMOVAL

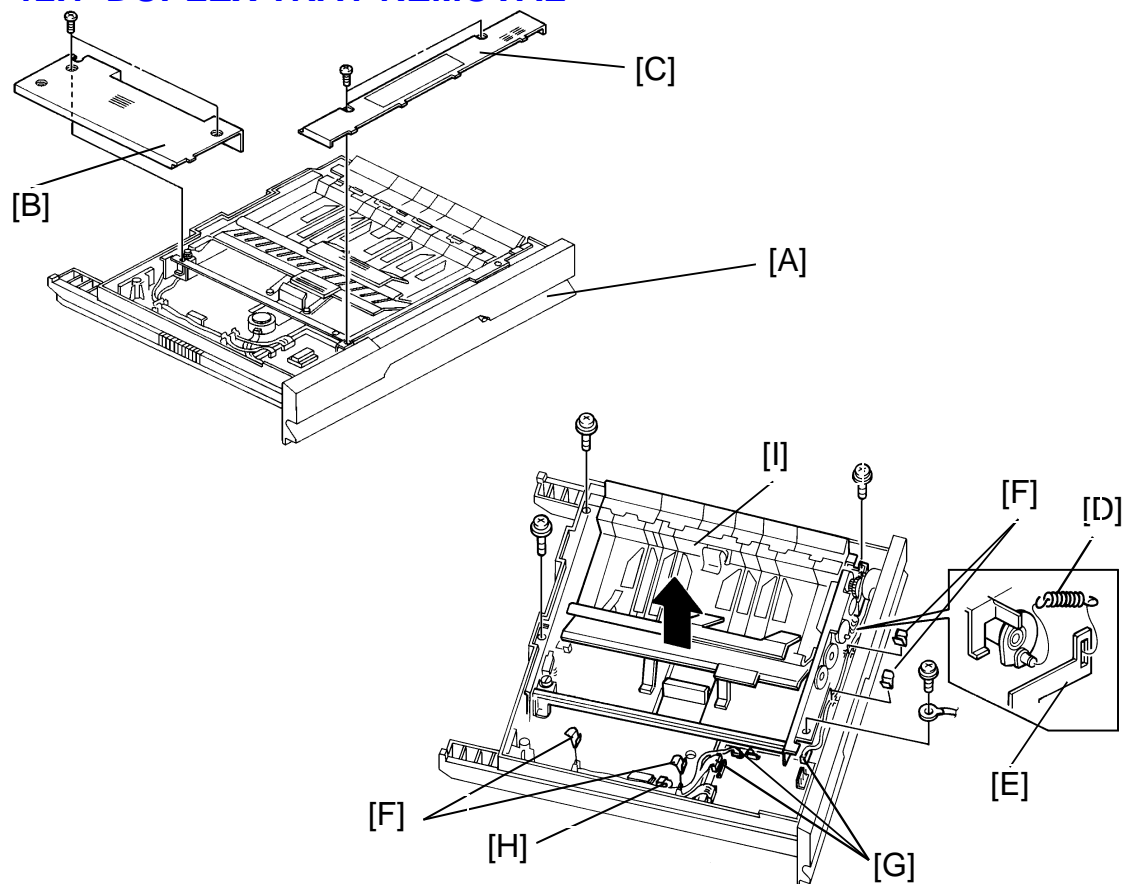

1. Pull the duplex tray [A] out from the copier.
2. Remove the side inner cover [B] (3 screws).
3. Remove the front inner cover [C] (2 screws).
4. Unhook the pressure spring [D] from the paper lift arm [E] and the eccentric cam.
5. Remove the clamps [F] with a pair of pliers.
6. Disconnect CN702, CN704, and CN706 [G] from the main board.
7. Disconnect the sensor connector [H] from the jogger home pos. sensor.
8. Remove the duplex unit [I] (4 screws and grounding wire) from the tray.

NOTE: Hold both sides of the duplex unit frame when lifting the duplex unit out of the tray.

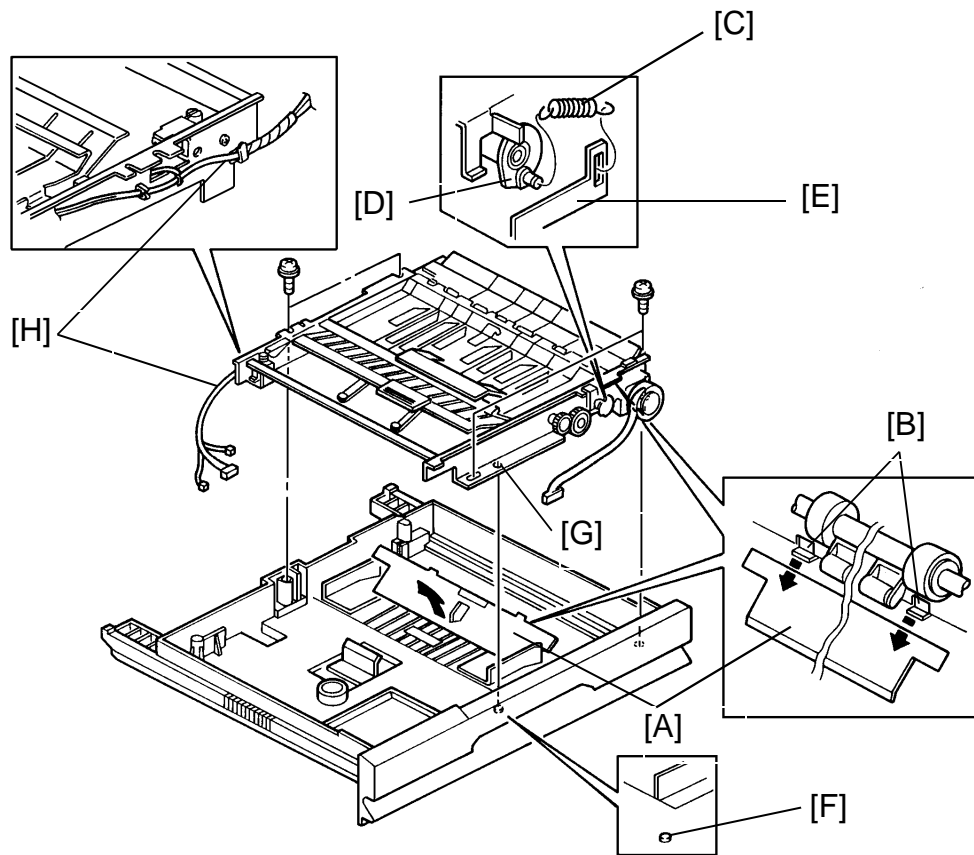

- Installation -

1. When placing the duplex unit back into the tray, hold up the bottom plate [A] so that the mylar brackets [B] fit under it as shown.
2. Hook the pressure spring [C] to the eccentric cam [D] and the paper lift arm [E] as shown.

NOTE: When installing the duplex unit, make sure of the following:

- a) Positioning pin [F] fits through hole [G] in the side plate.
- b) The sensor harness [H] is clamped correctly and is not caught under the unit frame.

12.2 JOGGER MOTOR AND JOGGER HOME POSITION SENSOR REPLACEMENT

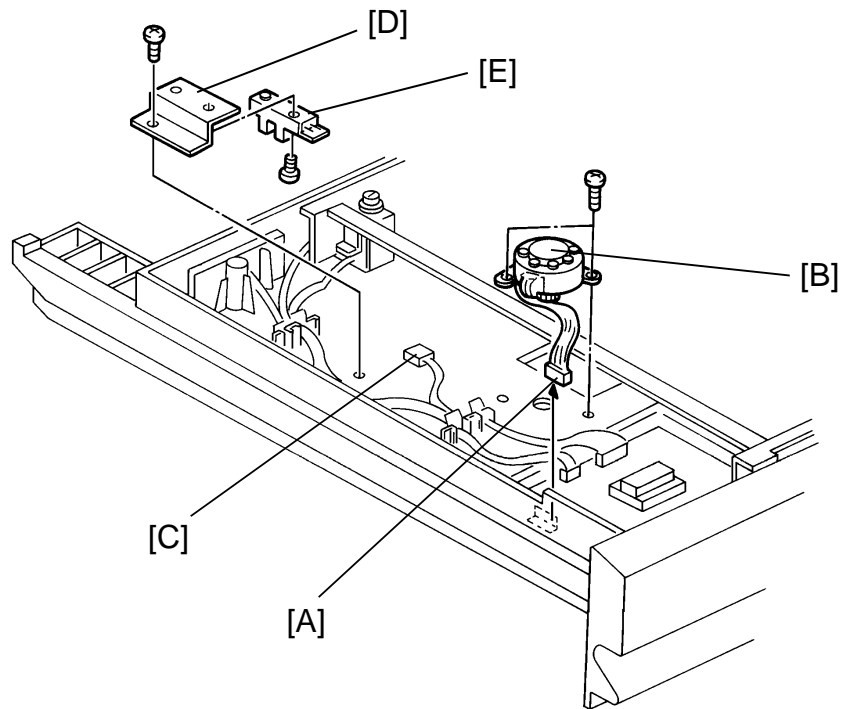

1. Remove the duplex tray.
2. Remove the front and side inner covers.

- Jogger Motor Replacement -

3. Disconnect CN705 [A] from the duplex main board.
4. Replace the jogger motor [B] (2 screws).

- Jogger Home Position Sensor Replacement -

3. Disconnect the sensor connector [C].
4. Remove the sensor bracket [D] (1 screw).
5. Remove the sensor [E] from the bracket and replace it (1 screw).

12.3 TURN SENSOR REPLACEMENT

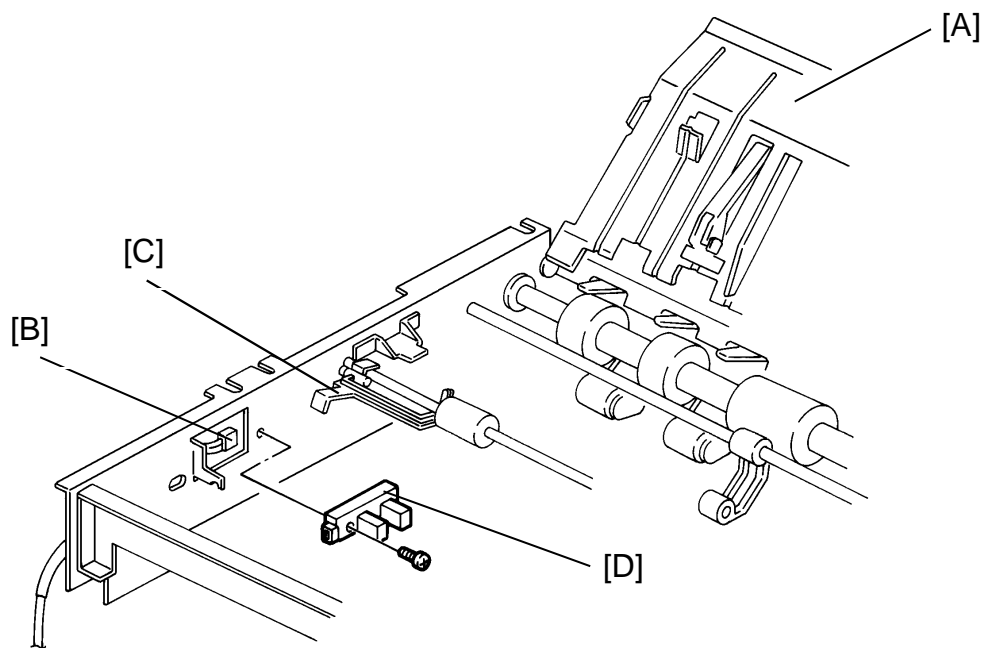

1. Remove the duplex tray.
2. Raise the upper and lower paper guides [A] all the way up.
3. Disconnect the turn sensor connector [B].
4. While lifting the sensor actuator [C], remove the sensor [D] (1 screw).

12.4 FEED MOTOR REPLACEMENT

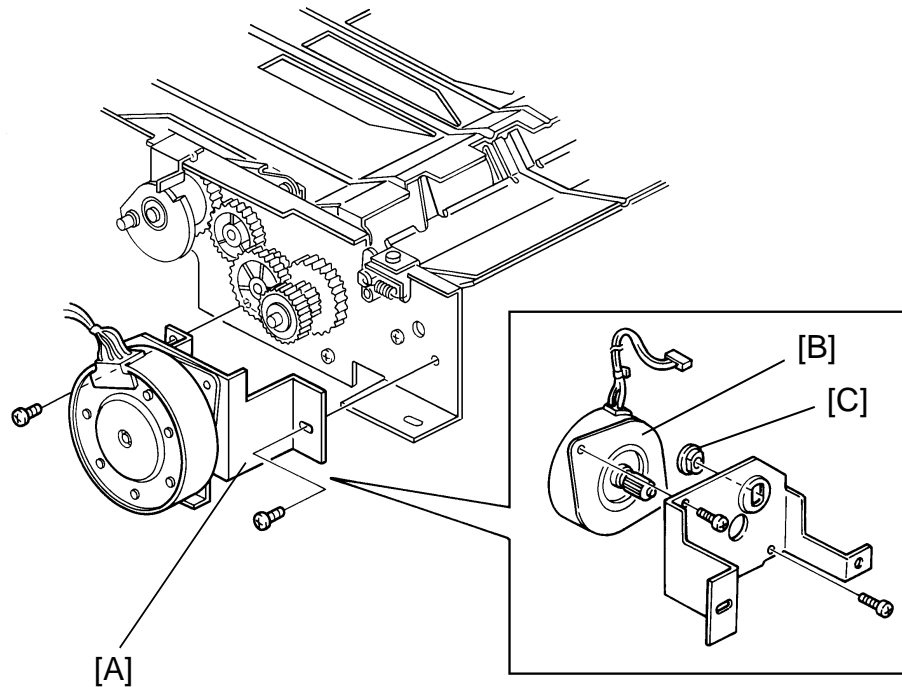

1. Remove the duplex unit from the tray. (See Duplex Unit Removal.)
2. Remove the paper feed motor bracket [A] (2 screws).
3. Replace the feed motor [B] (2 screws).

NOTE: When installing the paper feed motor, make sure that the bushing [C] is properly positioned between the bracket and the motor as shown.

12.5 PAPER END SENSOR REPLACEMENT

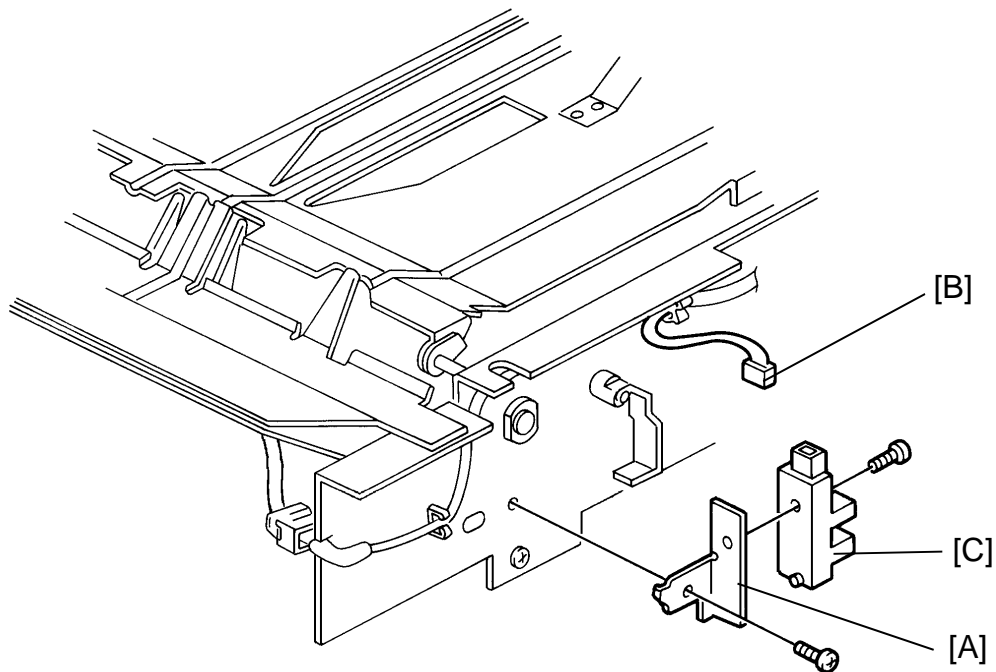

1. Remove the duplex unit from the tray. (See Duplex Unit Removal.)
2. Remove the paper end sensor bracket [A] (1 screw).
3. Disconnect the sensor connector [B].
4. Replace the sensor [C] (1 screw).

12.6 ENTRANCE SENSOR REPLACEMENT

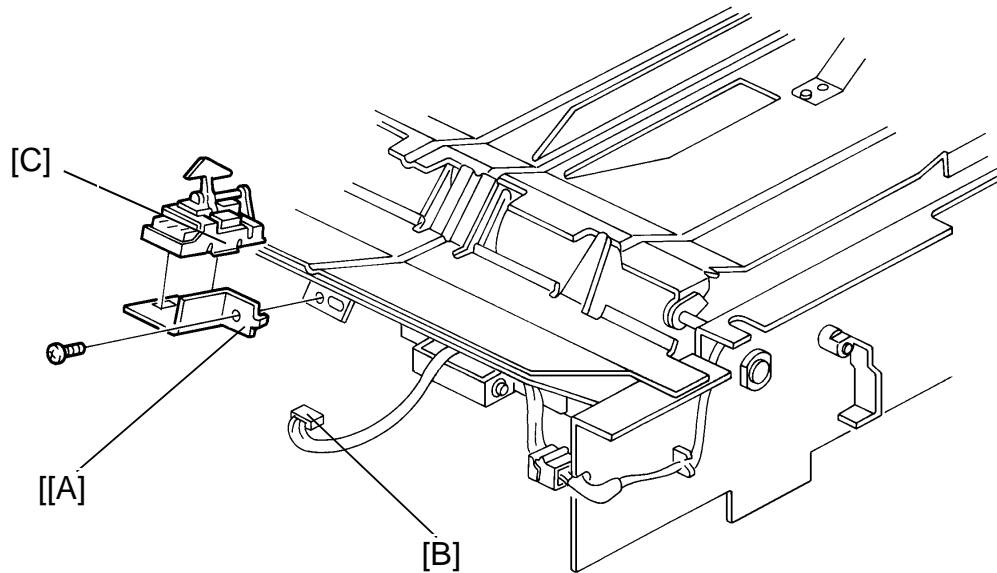

1. Remove the duplex unit from the tray. (See Duplex Unit Removal.)
2. Turn over the duplex unit as shown.
3. Remove the entrance sensor bracket [A] (1 screw).
4. Disconnect the sensor connector [B].
5. Replace the sensor [C].

12.7 GATE SOLENOID REPLACEMENT

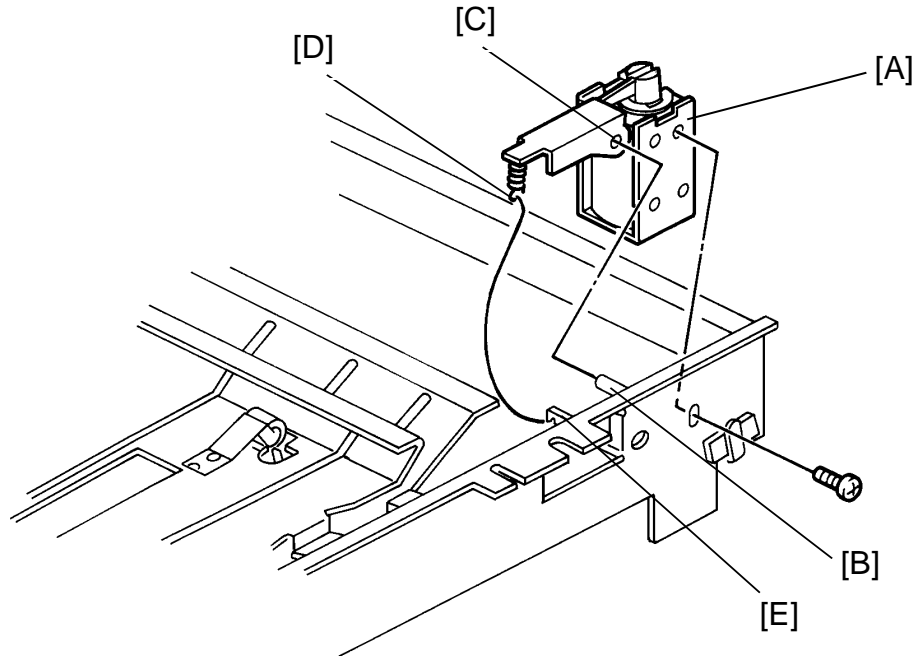

1. Remove the duplex unit from the tray. (See Duplex Unit Removal.)
2. Replace the gate solenoid [A] (1 screw).

NOTE: When installing a new solenoid, make sure of the following:

- a) Positioning pin [B] fits into the hole [C] on the gate solenoid actuator.
- b) Spring [D] is hooked to bracket [E].

12.8 FRICTION ROLLER REPLACEMENT

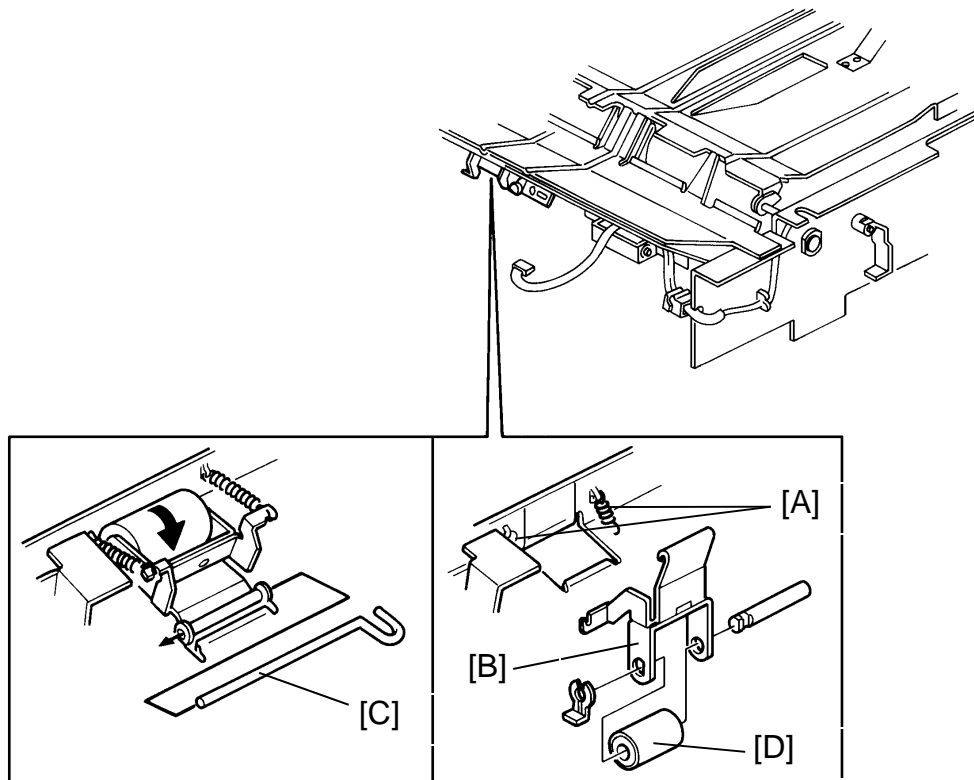

1. Remove the duplex unit from the tray. (See Duplex Unit Removal.)
2. Turn over the duplex unit as shown.
3. Unhook the springs [A] from the roller bracket [B].
4. Remove the lock pin [C] and the roller assembly.
5. Remove the roller [D] (1 snap-ring and shaft) from the bracket and replace it.

NOTE: This friction roller has a one-way clutch. Be sure to install the roller so that it rotates in the direction of the arrow. (See illustration.)

12.9 FEED ROLLER REPLACEMENT

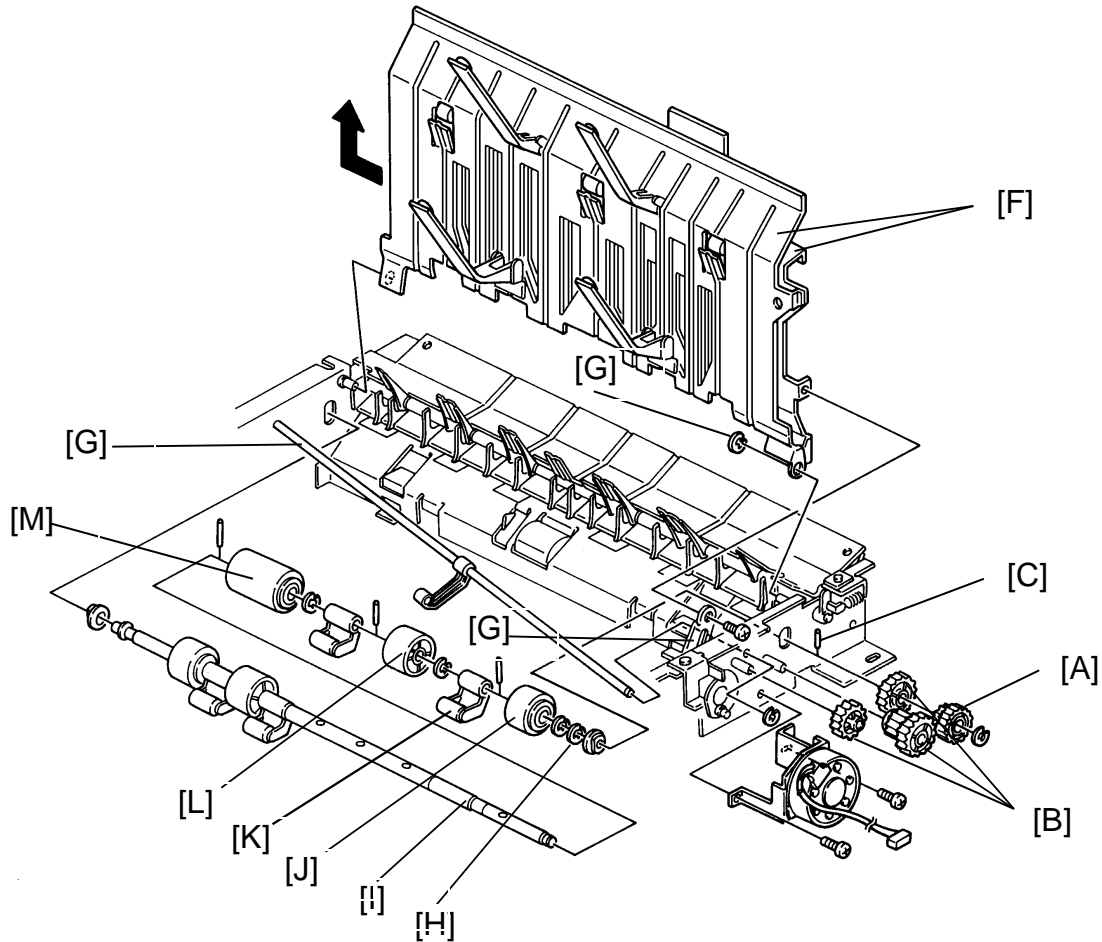

1. Remove the duplex unit from the tray. (See Duplex Unit Removal.)
2. Remove the feed motor. (See Feed Motor Replacement.)
3. Remove the drive gear [A] (1 E-ring) and three idle gears [B] (1 parallel pin [C]).
4. Remove the E-ring [D] and the upper paper guide plate stopper [E] (1 shoulder screw).
5. Remove the upper and lower guide paper plates [F].
6. Remove the paper end feeler shaft [G] (1 E-ring).
7. Remove the E-ring [H] on the front side of the feed roller shaft [I].
8. Remove the feed roller shaft (2 bushings).
9. Remove the feed support roller [J], flatter [K], paper retainer [L]; then, replace the feed roller [M] (1 E-ring and parallel pin per roller).

Duplex Unit Electrical Components

Index No.	Description	Symbol	P to P
1	Duplex Main Board	PCB1	E20
2	Jogger Motor	M2	I18
3	Jogger Home Position Sensor	S4	D19
4	Duplex Gate Solenoid	SOL1	I17
5	Duplex Entrance Sensor	S1	D18
6	Duplex Paper End Sensor	S3	D19
7	Duplex Turn Sensor	S2	D18
8	Duplex Feed Motor	M1	I19

Duplex Unit Connectors

Index No.	CN No.	Component	Symbol	Type	P to P
1	CN703	Duplex Main Board	PCB1	4P/W	E17 — F17
2	CN705	Duplex Main Board	PCB1	5P/W	G18
3	CN701	Duplex Main Board	PCB1	4P/T	F17
4	CN706	Duplex Main Board	PCB1	4P/W	G17
5	CN702	Duplex Main board	PCB1	13P/W	E19
6	CN721	Relay Connector for Duplex Gate	—	2P/W	H17
7	CN710	Solenoid	—	8P/B	E16 — F16
8	CN724	—	S1	3P/W	D18
9	CN726	Duplex Entrance Sensor	S2	3P/W	D18
10	CN723	Duplex Turn Sensor	S3	3P/W	D19
11	CN722	Duplex Paper End Sensor	—	3P/W	E18
12	CN704	Relay Connector for Duplex Turn Sensor	PCB1	6P/T	G19
		Duplex Main Board			

